

TORKLIFT **INTERNATIONAL**

OVER 35 YEARS OF INNOVATION, QUALITY, SAFETY.
IMPORTANT OWNER-OPERATOR INSTALLATION INSTRUCTIONS

A8020

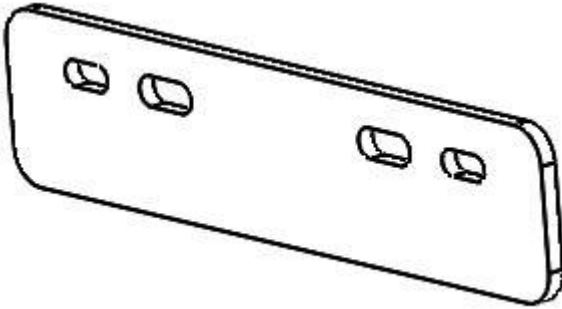

Version (02) BY: CW Date: 2/15/2016

TECH SUPPORT (800) 246-8132

**AFTER INSTALL, PLEASE GIVE
THIS BOOKLET TO YOUR CUSTOMER**







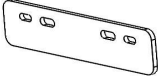
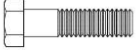

Warnings

Suspension

To significantly reduce body roll, sag and sway Torklift strongly recommends the StableLoad. Torklift International StableLoads improve safety, handling, and to help level your truck. More information can be found at (www.Torklift.com/stableload).

If your truck is additionally equipped with suspension air bags Torklift cautions against over pressurization as this may lead to unsafe vehicle handling characteristics. We have found that airbags used in conjunction with StableLoads have allowed operators to lower air bag pressure by 50% or more. Only pressurize suspension air bags enough to level the truck.

Parts Inventory

Item Image	Item Description	Quantity
	Spacer Plates with Tape	4
	3/8"-16x1.75" SS Bolt	4
	3/8"-16 Nut	4
	3/8" SAE SS Washer	8
	3/8" Lock Washer	4
	5/16"-18x1.75" SS Bolt	4
	5/16"-18 Nut	4
	5/16" SAE SS Washer	8
	5/16" Lock Washer	4

Instructions

Step 1

Measure the width between the brackets that the GSR will be installed in. Use the Table 1.1 for 25.5" (A810x) and Table 1.2 for 27.5" (A800x) GSR installations.

Bracket Width for 25-1/2" GSR	=	Number of Spacers
25-3/4" to 25-15/16"	=	1
26" to 26-3/16"	=	2
26-1/4" to 26-7/16"	=	3
26-1/2" to 26-3/4"	=	4

Table 1.1

Bracket Width for 27-1/2" GSR	=	Number of Spacers
27-3/4" to 27-15/16"	=	1
28" to 28-3/16"	=	2
28-1/4" to 28-7/16"	=	3
28-1/2" to 28-3/4"	=	4

Table 1.2

Step 2

Remove the protective film covering from the preinstalled tape on the GSR Spacer Plate. Adhere an even number of GSR Spacer Plates on each side of the GSR where possible. Each side may use up to two GSR Spacer Plates.

Step 3

Use the appropriate size of hardware for your step and install the GSR. Use the correct holes for the bolt size as shown in Figure 3.1. Firmly pressing the GSR Spacer Plates to the sides of the GSR, assemble the GSR as shown in Figure 3.1 and 3.2.

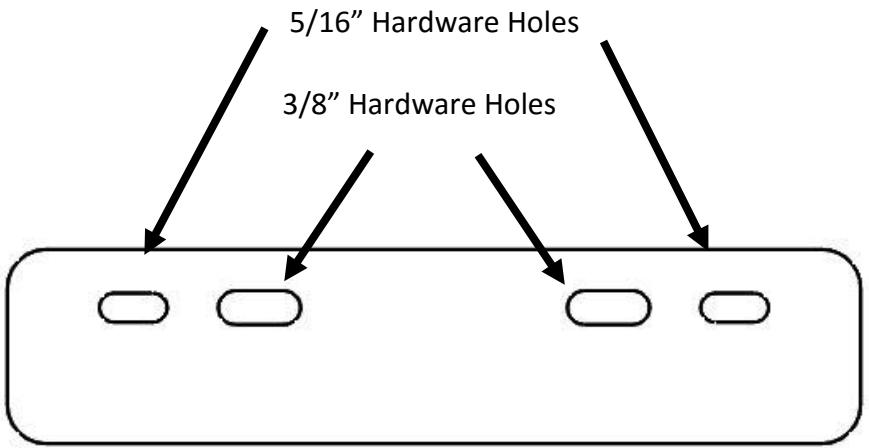

Figure 3.1

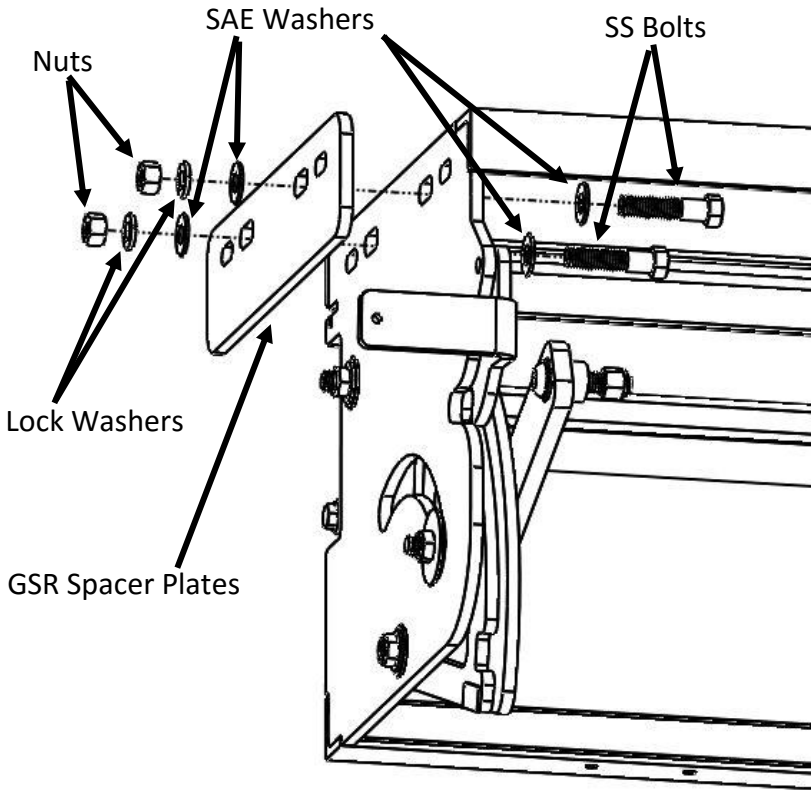

Figure 3.2 (3/8" hardware shown, when using 5/16" hardware use the 5/16 holes shown in Figure 4.1)

Step 4

Continue with GSR installation per instructions included with your steps.

Torklift International Limited Lifetime Warranty Information

322 Railroad Ave North, Kent, WA 98032

Torklift will require proof of purchase to register, with pictures of any defective product before issuing a replacement. Torklift will not register any product without proof of purchase, which can be faxed, scanned, emailed, or mailed to the information provided below. Torklift warrants its hitches, custom hitch receivers, frame mounted tie downs, turnbuckles, and accessories (excluding wire harnesses which carry a 90 day warranty) from date of purchase against defects in material and workmanship under normal use and service for the ownership life of the original consumer purchaser. All plastic, rubber, and/ or electrical components maintain a warranty of up to one year from the date of the purchase. **ALL COMMERCIAL APPLICATIONS ARE WARRANTED FOR A PERIOD OF 90 DAYS FROM THE DATE OF INSTALLATION/SERVICE.** Torklift will replace **FREE OF CHARGE** any part which proves defective in material or workmanship when presented to Torklift, **TRANSPORTATION CHARGES PREPAID** by purchaser, at the address above. **THIS WARRANTY IS LIMITED TO DEFECTIVE PARTS REPLACEMENT ONLY. LABOR CHARGES AND/OR DAMAGE INCURRED IN INSTALLATION OR REPLACEMENT, AS WELL AS INCIDENTAL AND CONSEQUENTIAL DAMAGES CONNECTED THEREWITH ARE EXCLUDED.** This warranty does not include the finish or paint on our products. Rusting, cracking or peeling of the finish is also excluded. Some states do not allow the exclusion or limitation of incidental or consequential damages, so the above limitation or exclusion may not apply to you. Any damage to Torklift products as a result of misuse, abuse, neglect, accident, improper installation or any use violative of instructions furnished by Torklift or **WHEN USED IN ANY COMMERCIAL APPLICATION WILL VOID THE WARRANTY.** This warranty gives you specific legal rights, and you may also have rights which vary from state to state. With warranty service, you may be able to go to a small claims court, a state court or a federal district court.

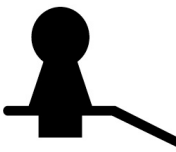

TORKLIFT™

INTERNATIONAL

322 Railroad Ave North, Kent, WA 98032

Phone (800) 246-8132 Fax (253) 854-8003

Or visit our website: www.TorkLift.com

Dear Valued Customer,

Thank you for making TorkLift your choice for truck, camper packages and accessories for your vehicle. By choosing TorkLift products, you have chosen a company that has been serving the RV industry for nearly 40 years and whose name has become synonymous with strength, quality and advanced design and installation.

Please take a few moments of your time to complete the Product Registration Warranty Card on the next page. When registering your newly purchased TorkLift products, you can be assured that your contact information is secure and that you and your product are getting the attention and respect that you deserve.

Thank you again for choosing TorkLift quality products.

Register for your lifetime warranty and receive a free Torklift International gift.

To Fax: Send copies of the questionnaire, warranty card and receipt to
253-854-8003

To E-mail: Send copies of the questionnaire, warranty card and receipt to
warranty@torklift.com

To Mail: Send to Torklift International 322 Railroad Ave North, Kent, WA 98032



OFFICIAL WARRANTY REGISTRATION CARD

322 Railroad Ave North, Kent, WA 98032

PLEASE FILL OUT THIS FORM COMPLETELY AND RETURN TO TORKLIFT WITHIN
30 DAYS OF PURCHASE ACCOMPANIED BY A COPY OF YOUR ORIGINAL RECEIPT

1. PART(S) PURCHASED

TODAY'S DATE: _____

PART #: _____ PART #: _____
PART #: _____ PART #: _____
PART #: _____ PART #: _____

2. PURCHASER INFORMATION

NAME: _____
ADDRESS: _____

CITY: _____ STATE: _____ ZIP / POSTAL CODE: _____
PHONE: (____) _____ - _____ EMAIL: _____

3. TRUCK INFORMATION

YEAR: _____ MAKE: _____
MODEL: _____ BED LENGTH: _____

4. CAMPER INFORMATION

YEAR: _____ MAKE: _____ MODEL: _____

5. DEALER INFORMATION

PURCHASED FROM: _____
ADDRESS: _____

CITY: _____ STATE: _____ ZIP / POSTAL: _____
INSTALLED BY: _____ OWNER ABOVE DEALER ANOTHER DEALER

IF ANOTHER DEALER, WHO: _____